



Presentation on interim financial results of financial year 2024.

Nov.22, 2023



Y.A.C. HOLDINGS Co., Ltd.

(ZIP : 6298 TSE Prime)

<https://www.yac.co.jp>

▲ Notes regarding future prospect.

The prospects described in this document is based on the information we have as of the time this document is published, and the actual result may differ from such prospects due to various unexpected factors.

semiconductor business which we are involved is the business that technical innovation speed is very fast and very competitive. The forecasted figures stated in this material are based on the information currently available to us and certain assumptions that are regarded as legitimate. And world economy conditions, movement of foreigner exchange rate, market condition and new capital investment movement will influence directly to our business. We do not promise that the forecasts or estimates will be accurate. Large discrepancies may be seen in the actual results due to various factors.

Contents

1.Greetings	MOMOSE Takefumi Representative Director, Chairman and President, Y.A.C.HOLDINGS CO., LTD.
2.Summary of financial results of 6 months ended from Apr.1 st ,2023.	HATAKEYAMA Osamu, Director a board member of Y.A.C. HOLDINGS CO., LTD.
3.Outline of financial results of 6 months ended from Apr. 1 st , 2023.	HATAKEYAMA Osamu, Director a board member of Y.A.C. HOLDINGS CO., LTD.
4-① Mechatronics related business.	ITO Toshihiko, Deputy President, Y.A.C. HOLDINGS CO., LTD.
4-② Display related business.	AOKI Yasuhiro, President, YAC DENKO Co., Ltd.
4-③ Industrial machinery business.	SOEJIMA Yukio, President, Y.A.C. Machinery Co., Ltd.
4-④ Electronics related business.	OHKURA Akihiro, President, Ohkura Electric Co., Ltd.
5.Future development of YAC Group.	MOMOSE Takefumi, Representative Director, Chairman and President, Y.A.C.HOLDINGS CO., LTD.
6.Q&A	

1. Greeting.

MOMOSE Takefumi,

Representative Director,

Chairman and President,

Y.A.C. HOLDINGS CO., LTD.

1. Greetings



1. Very Thanks for your support.

On May 11, 2023, we were able to safely celebrate our 50th anniversary. We would like to thank everyone for your long-term support so far, and ask for your continued guidance.

2. Highest sales and highest profit.

We have been aiming for record high sales and profits in the year of our 50th anniversary, but this year we may face difficult conditions. This will continue to be our goal from next year onwards.

3. Tokyo Stock Exchange Prime Market.

We Selected the prime market due to TSE reorganization. We were able to significantly clear the stock price (market capitalization), which was the only condition that was not met. We will not be satisfied with this and will continue to strive to further increase our stock price.

4. Dividend.

In the previous fiscal year (ended March 2023), the annual dividend was 75 yen, including the 50th anniversary commemorative dividend (25 yen). The company plans to maintain the annual dividend of 75 yen this fiscal year (ending March 2024).

A decorative banner at the top of the slide features a collage of images: a golden gear, a grid pattern, a colorful aurora, a bright sun flare, a road with solar panels, and a person in a suit.

**2. Summary of financial results 6
months ended from Apr.1, 2023.**

HATAKEYAMA Osamu

**Director and Managing Operating
Officer,**

Y.A.C. HOLDINGS CO., LTD.

2 - ① Summary



1. Overall overview.

As of now, the financial results for the second quarter are progressing smoothly with "increase in sales and profits"
On the other hand, due to "sluggish sales growth" influenced by the sluggish orders and the economic slowdown in China,
The full-year earnings forecast has been revised downward.

2. Each level income.

(1) Gross profit

In addition to quantitative effects such as increased sales and cost reductions, combined with qualitative effects such as improved gross profit margin. Second quarter gross profit reached the 3 billion yen level, the highest level in the last 10 years.

(2) Operating income

In addition to increased expenses at JE (Gifu) and GD (Korea), which joined the group from this fiscal year, increased labor costs due to a wage increase (4% UP) and other expenses offset the gross profit increase effect. As a result, operating income increased 50% year on year to 710 million yen.

3. Main topics in the second quarter financial results.

Regarding Lynas, one mounter was shipped on August 10th. Currently in operation at NJ Lab. Okura Electric acquired a distributor in the Hokkaido area. Recorded negative goodwill of 263 million yen.

4. About order status.

Orders received (flow): 10.3 billion yen, down 32% compared to the same period last year. Orders received (stock): 24.3 billion yen, an increase of 4% compared to the end of the same period last year.
— This leads to a twisting phenomenon where there is lameness between both flow and stock.

5. Full-year performance forecasts and dividend forecasts.

(1) Full-year forecast.

Full-year earnings forecasts have been revised downward due to sluggish sales growth due to sluggish orders and delays in capital investment. The decline in profits at each stage is mainly due to "reduction factors"

(2) Full-year dividend forecast.

Although the profit is lower than the initial forecast, the decline in net profit is limited, so the full-year dividend forecast remains unchanged at 75 yen per year.

**3. Outline of financial results 6 months
ended from Apr.1,2023.**

HATAKEYAMA Osamu,

**Director and Managing Operating
officer,**

Y.A.C. HOLDINGS CO., LTD.

3 - ① Consolidated P/L Summary



【Topics】

Sales & Profit increased : Due to the combination of increased sales and cost reductions, gross profit improved in both amount and percentage. As a result, overall profits increased
 Gross profit increase (+518M) = Margin improvement factor (+389M) + Sales increase factor (+129M)

(Millions of ¥)

	① 6 months ended Sep. 2021	② 6 months ended Sep.2022	③ 6 months ended Sep.2023	Year on Year comparison (③-②)		Forecast (as of 23/5/13) Progress (100 Millions ¥)
				Increase (Decrease)	Increase ratio (decrease ratio)	
Sales	11,075	10,976	11,506	530	4.8%	31% (370)
Gross profit	2,909	2,671	3,189	518	19.4%	
Gross margin	26.3%	24.3%	27.7%			
Operating income	716	473	710	237	50.2%	19% (37)
Ratio	6.4%	4.3%	6.2%			
Ordinary income	730	577	861	283	49.1%	24% (36)
Profit for the period	524	325	700	374	115%	30% (23)

3 - ② Consolidated P/L as references



【Historical profit & loss for past 6 years】

Gross profit is the 10 years historically highest due to improvement of profit ratio.

(Millions of ¥)

	6 months ended Sep.2018	6 months ended Sep.2019	6 months ended Sep.2020	6 months ended Sep.2021	6 months ended Sep.2022	6 months ended Sep.2023
Sales	15,977	11,952	12,230	11,075	10,976	11,506
Gross profit	2,678	1,824	2,440	2,909	2,671	3,189
Gross margin	16.8%	15.3%	20.0%	26.3%	24.3%	27.7%
Operating income	326	-553	311	716	473	710
Ratio	2.0%	-4.6%	2.5%	6.5%	4.3%	6.2%
Ordinary income	428	-622	307	730	577	861
Ratio	2.7%	-5.2%	2.5%	6.6%	5.3%	7.5%
Profit for the period	161	-710	273	524	325	700

3 - ③ Consolidated P/L Segment information

【Topics】

The display division posted consecutive operating profits in 1Q (+56M) and 2Q (+248M) after the April 1 merger.

(Millions of ¥)

	Segment				Sub total	Adjustment	Total
	Mechatronics	Display	Industrial machinery	Electronics			
Sales/ Sep.2021	6,055	952	371	3,696	11,075		11,075
Operating income Ratio	678	-201	-49	179	606	109	716
Sales/ Sep.2022	5,179	2,513	416	2,866	10,976		10,976
Operating income Ratio	469	-131	-17	103	424	48	473
Sales/ Sep.2023	4,978	1,973	493	4,060	11,506		11,506
Operating income ratio (1 st Q	580	248	-244	362	946	-236	710
Operating income ratio)	183	56	-152	58	146	-134	11

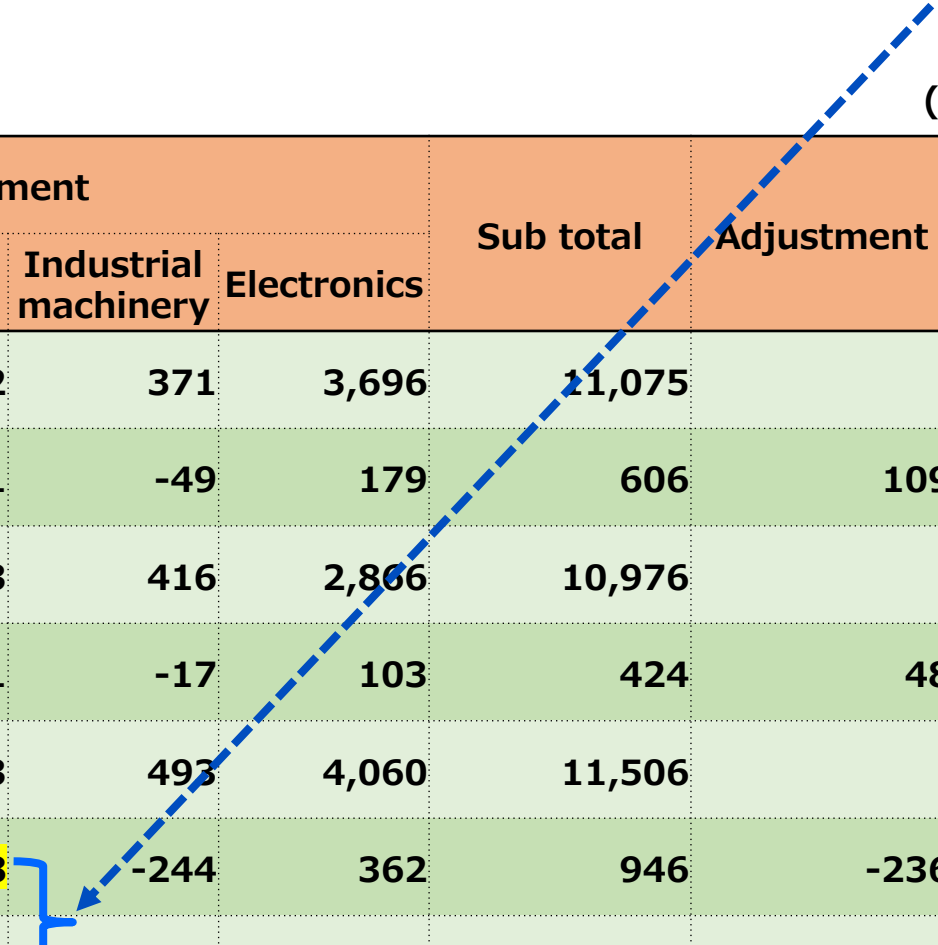

3 - ④ Sales by region and segment.

【Topics】

Currently, sales to China are decreasing remarkably.

	① 6 months ended Sep. 30, 2022				② 6 months ended Sep. 30, 2023				Increase decrease total
	Mechatronics	Display	Industrial machinery	Electronics	Mechatronics	Display	Industrial machinery	Electronics	
Japan	3,012	810	365	2,787	3,179	1,478	418	3,970	+2,070
P.R.C.	599	1,425	20	6	301	458	4	0	-1,286
Other Asia	1,521	173	17	70	714	19	63	88	-896
Others	45	104	13	2	782	17	7	1	+642
Total	5,179	2,513	416	2,866	4,978	1,973	493	4,060	+530

3 - ⑤ Consolidated B/S



(Millions of ¥)

	AS of Sep.30, 2022	AS of Mar.31, 2023	AS of Sep.30, 2023	Increase(Decrease)
Current assets	28,097	30,108	31,592	1,483
Noncurrent assets	8,217	8,631	10,573	1,941
Assets total	36,315	38,740	42,165	3,424
Current liabilities	13,798	13,680	17,272	3,592
Fixed liabilities	6,805	9,082	8,375	▲707
Liabilities total	20,604	22,763	25,648	2,884
Net assets total	15,711	15,977	16,517	539

【Topics】

While assets and liabilities increased in both terms (3.4 billion yen), the increase in net assets was only a slight increase (+500 million yen), resulting in a deterioration in the equity ratio.

	Mar.31, 2021	Sep.31, 2021	Mar.31, 2022	Sep.31, 2022	Mar.31, 2023	Sep.31, 2023	Increase (Decrease)
Equity ratio	37.5%	42.0%	41.3%	43.2%	41.1%	39.1%	-2%

3 - ⑥ Consolidated cash flow



【Topics】

The deterioration in operating C/F is due to working capital factors. Operating C/F (-87M) = Profit and loss factor (+890M) + Working capital factor (-977M)

(Millions of ¥)

	6 months ended Sep.2021	6 months ended Sep.2022 I	6 months ended Sep.2023 II	Increase/Decrease II - I
①Cash and cash equivalents balance at beginning of period	9,932	8,619	6,552	
Cash flows from operating activities	+566	+523	-87	-611
Cash flows from investment activities	-54	-171	-1,893	-1,721
Cash flows from financial activities	-2,053	-1,904	+1,095	+2,999
Foreign currency	+48	+109	62	47
②Cash and cash equivalents balance at end of period.	8,439	7,176	5,728	
②-①Increase /Decrease	-1,493	-1,442	-823	

3 - ⑦ Status about new order received.

【Topics】

New order received in Sep. : Big decrease comparing to the previous same period(-4.8 Billion¥)

Backlog ordered as of end of Sep. : Increase comparing to the previous same period, however decrease comparing to the previous Mar. end by 1.1Billion¥

(Millions of ¥)

	Results of 6months ended Sep. 2021		Results of 6months ended Sep. 2022		Results of 6months ended Sep. 2023		Remarks
	New order received	Backlog ordered	New order received	Backlog Ordered	New order received	Backlog ordered	
Mechatronics	5,624	2,807	7,447	6,792	4,928	7,462	
Display	2,939	5,742	2,718	6,869	632	7,201	
Industrial machinery	438	226	560	267	743	394	
Electronics	3,849	6,338	4,460	9,456	4,043	9,268	
Total	12,851	15,114	15,187	23,385	10,348	24,327	Mar.2024 25,485

3 - ⑧ Consolidated financial forecast revision for the year ending Mar.31, 2024

Consolidated financial forecast revision for the year ending Mar.31, 2024 (Apr.1, 2023 to Mar.31, 2024)

	Sales	Operating income	Ordinary income	Profit attributable to owners of parent	Net income per share
Previous forecast (A)	37,000	3,700	3,600	2,300	¥249.91
Revised forecast (B)	30,000	3,000	2,900	2,100	¥228.64
Change (B-A)	- 7,000	-700	-700	-200	—
Change Ratio (%)	-18.9%	-18.9%	-19.4%	-8.7%	—
Result for the year ended Mar.31 2023	24,114	1,495	1,541	921	¥100.57

<Reasons for financial forecast revision>

1. Sales are predicted to be lower than the previously announced forecast due to sluggish sales caused by a combination of delays and deterioration in delivery dates of backlog of orders influenced by turmoil in foreign exchange and financial environments in Japan and overseas, as well as slump in orders due to economic deterioration in China.
2. Regarding operating income, we are making efforts to reduce manufacturing costs such as material procurement prices and processing costs, and although we can see some successful results, operating income is forecasted to be lower than the previously announced forecast due to the significant impact of the decrease in sales mentioned above.
3. Ordinary income is also forecasted to be lower than the previously announced forecast due to the impact of a decrease in operating income.
4. Regarding net income attributable to owners of the parent company, although there will be an impact from a decrease in operating income, the amount of decrease is expected to be mitigated by gains on negative goodwill arising from corporate acquisitions by subsidiaries.

Notes:

The forecasted figures stated above are based on the information currently available to us and certain assumptions that are regarded as legitimate. We do not promise that the forecasts or estimates will be accurate. Large discrepancies may be seen in the actual results due to various factors.

Regardless to this revision, we do not intend to revise annual cash dividend at this moment.

3 - ⑨ Cash dividend to be paid forecast

【Topics】

No revision, planning to pay ¥75 per share.

	Dividend per share			Profit per share	Dividend pay out ratio
		2 nd quarter end	Year-end		
Sep. 2022	¥36	¥12	¥24	¥121.49	22.1%
① Mar. 2023	¥75	¥25	¥50	¥100.57	74.6%
② Mar. 2024	¥75	¥35	¥40	¥228.64	32.8%
Increase /Decrease ② - ①		¥10	-¥10	-	-

Segment information.

4 - ① Mechatronics related business.

ITO Toshihiko,

Director and Deputy President,

Y.A.C. HOLDINGS CO., LTD.

Representative director and President,

Y.A.C. MECHATRONICS CO., LTD.

4 - ①

Mechatronics related business

(1st half of a year analysis)



6 months ended Sep.2023

● Y on Y, Sales decreased by 4% however profit increased by 24%.

● Analysis

- ① HDD related new capital investment was still postponement.
- ② Clean conveyer and other automatic conveyer machine and ion beam are stable.
- ③ Customers postponed capital investment due to slump in the electronic parts market, therefore sales of carrier tape, taping equipment decreased.
- ④ Equipment for the semiconductor industry, including power semiconductor, is performing well.
- ⑤ Manufacturing period became longer due to longer delivery time of parts.
- ⑥ The backlog of orders at the end of the previous fiscal year exceeded 7.5 billion, but the budget was not achieved.

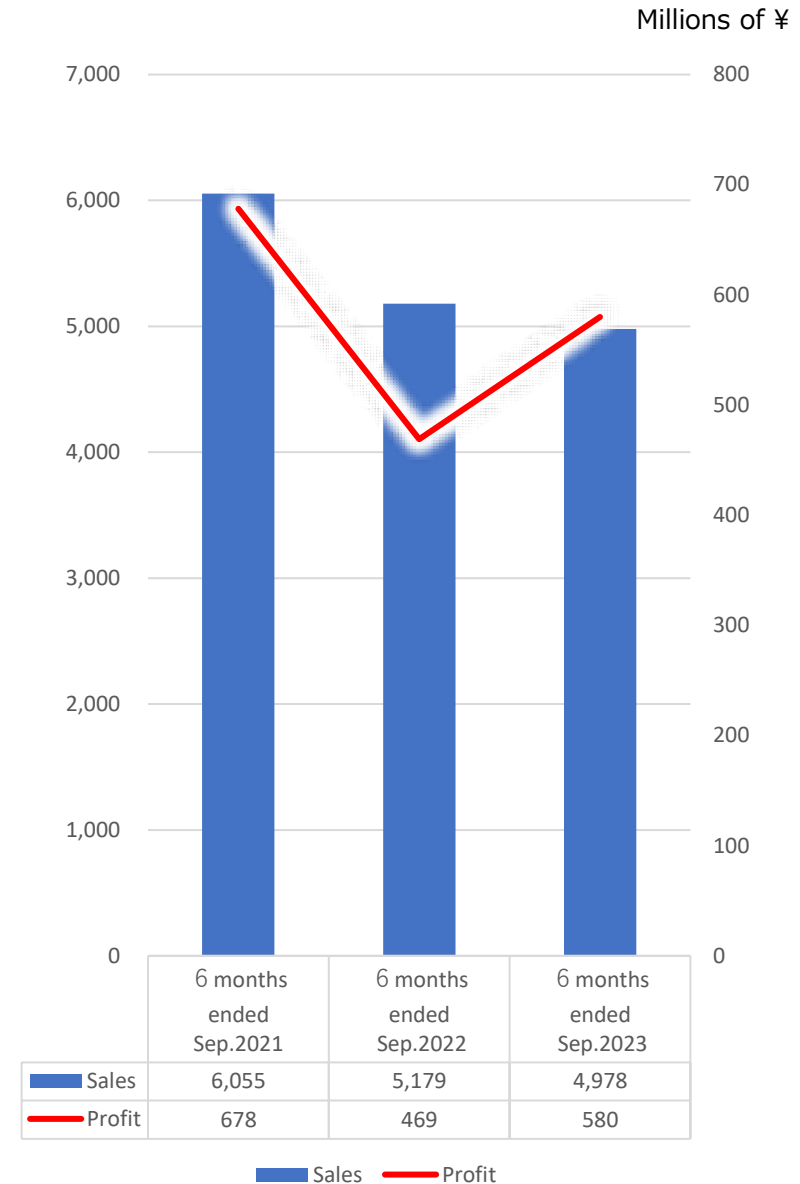

Targets of the FY Mar.2024 and measure

● **Sales: ¥13,500 million.**

● **Concern.**

- ① New capital investment for HDD may be postponed this year either.
- ② Electronics related business may gradually recover.
- ③ Continuously manufacturing time equipment may be long.

● **Measures.**

- ① Concentrate into well power semiconductor related business.
- ② Carrier tape will be produced with the right material in the right place and in a timely capital investment, high price sales with added value
- ③ Increasing gross profit by reducing costs through centralized purchasing effects.

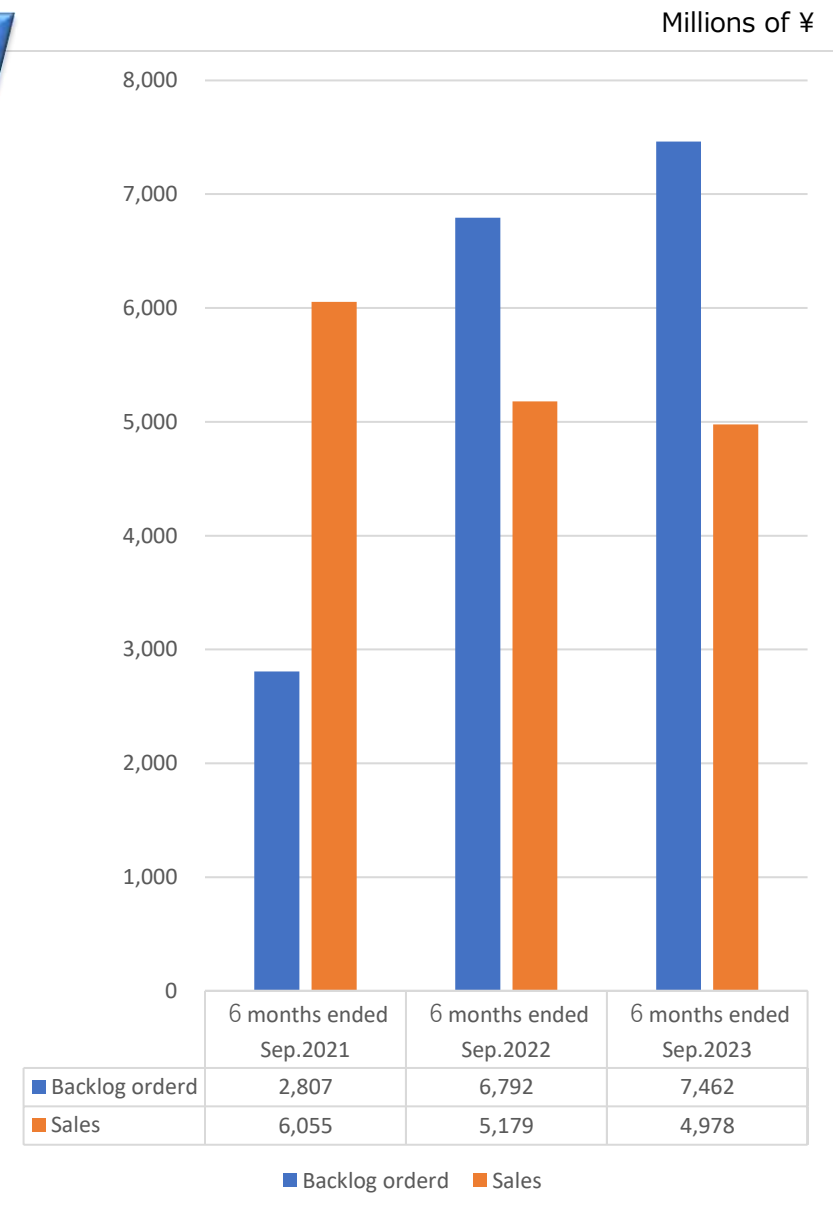

Segment Information.

4 - ② Display related business.

AOKI Yasuhiro

Operating Officer,

Y.A.C. HOLDINGS CO., LTD.

Representative Director & President,

YAC Denko Co., Ltd.

6 months ended Sep.2023

■ Market.

In the display market, the recovery of panel demand will be delayed, and capital investment will tend to be postponed until next fiscal year. Expectations are high for capital investment as OLED panels for IT use larger panel.

■ Segment trends.

- ① The two companies in this segment were merged on April 1, 2023, aiming to improve productivity and profitability by pursuing economies of scale and reorganizing and consolidating operations.
- ② Sales decreased mainly due to delays in plans for dry etching equipment, but projects for heat treatment equipment and consumables services proceeded as planned and profits increased (became profitable).
- ③ Orders for industrial heat treatment equipment increased due to increased demand for electric heaters to support decarbonization and replacement demand for electronic component manufacturing equipment.

単位：M円

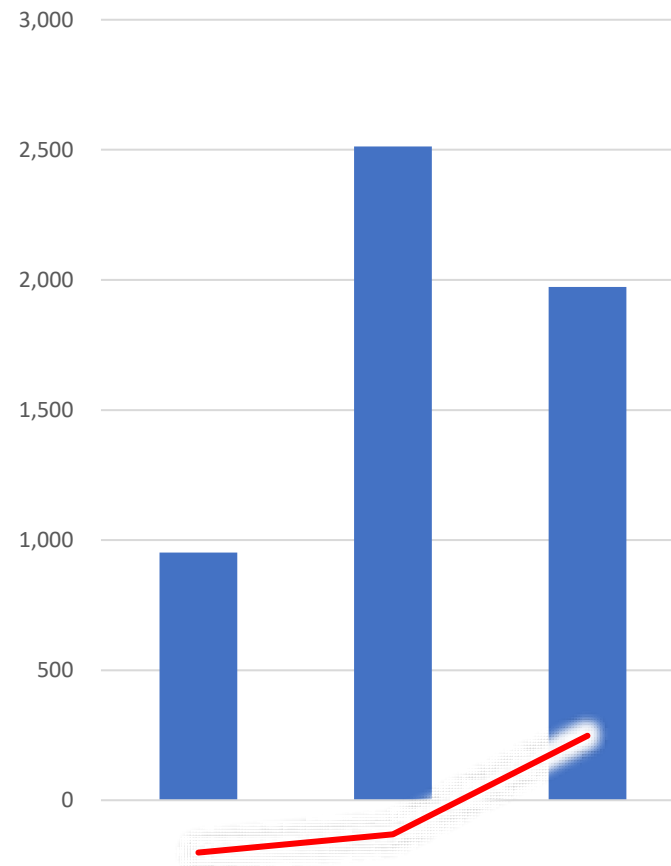

(500)

	6 months ended Sep.2021	6 months ended Sep.2022	6 months ended Sep.2023
Sales	952	2,513	1,973
Profit	-201	-131	248

■ Sales ■ Profit

Target of this FY year and measures

- Sales : ¥6 Billion.
- Concerns
 - ① Further postpone new capital investment for FPD manufacturing facilities.
 - ② Delay of recovery of display panel.
 - ③ Further down of gross margin due to material hike.
- Measures :
 - ① Sales strategy based on high value-added process adaptation.
 - ② Expansion of after-sales services due to improved equipment operation.
 - ③ Manage costs and delivery dates by standardizing parts and inventory.
 - ④ Expanding sales channels of plasma application equipment, heat treatment equipment for various industries other than displays.

Millions of ¥

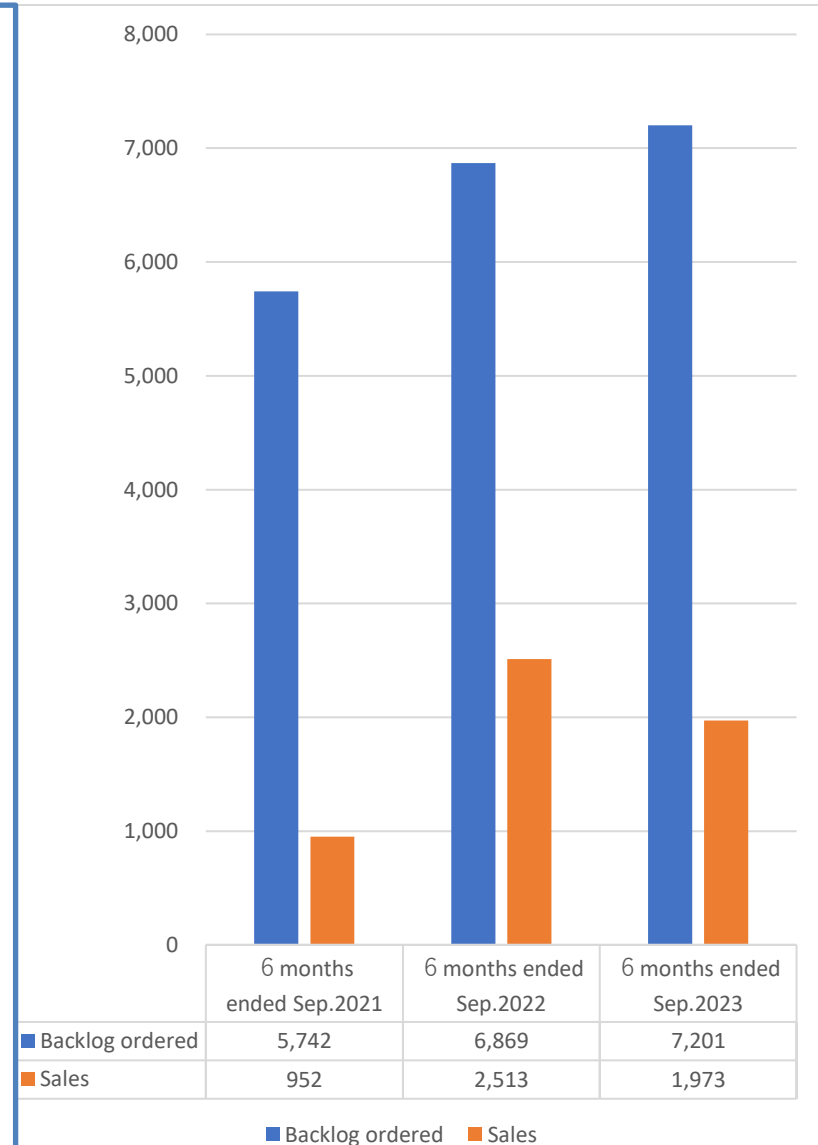

Segment information.

4 - ③ Industrial machinery.

SOEJIMA Yukio

Operating Officer,

Y.A.C. HOLDINGS CO., LTD.

Representative Director & President

Y.A.C. MACHINERY CO., LTD.

6 months ended Sep. 2023

We absorbed JE International-related business in April, but orders decreased. As a result, the deficit became big.

- In the home cleaning business, the number of factories has shrunk, resulting in higher operating rates and service sales profits.

- In industrial cleaning, we focused on medical linen and expanded equipment horizontally, with orders for tunnel finishing machines increasing in particular.

- We are focusing on e-commerce logistics, and major users are using our packaging system. We are explaining this to each company in order to carry out further expansion.

In order to solve the "24-year logistics problem", automatic packaging machines that save labor are a necessary item.

- JE International's orders have shifted. The feature of double-sided AOI is that it doubles the throughput speed, so it is being shifted to other industries.

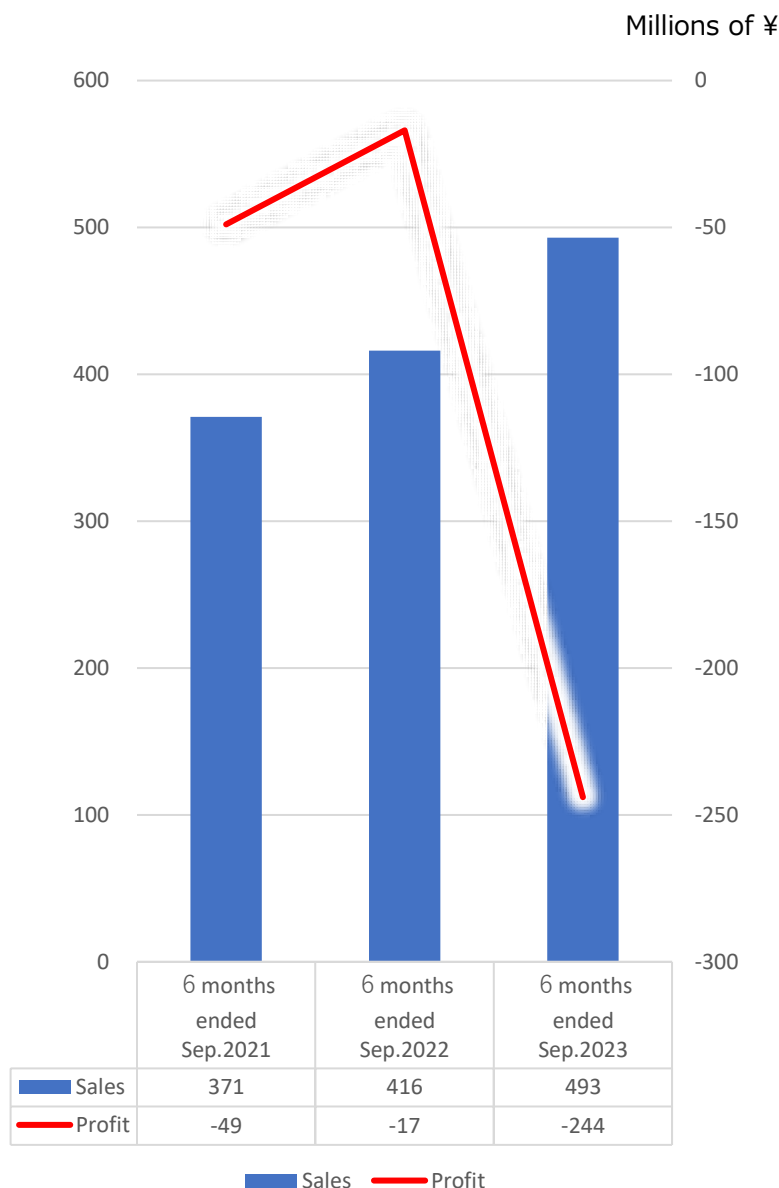

Target of this FY and measures

● Sales: ¥1.5 Billion.

- Increase orders for home cleaning services. In the first half, factories operate and services increased. Demand for the equipment will start in the second half of the year, so we will have a system in place for immediate delivery.
- Industrial cleaning has replaced medical linen with growth in hotel linen due to inbound demand. Although we are considering new models, we will expand sales of current products.
- We are focusing much more on EC logistics. We announced a new product the other day, and we would like to use compression packaging to reduce the volume to 1/2 and reduce shipping costs to 1/2. As a result, CO2 emissions will be half, so we would like to sell it to the e-commerce logistics industry, apparel industry, packaging material industry.
- JE International's AOI has a proven track record in FPCB (flexible printed circuit boards). The company is working to promote orders as it is expected to replace FPCBs in wire harnesses, especially for EV applications where weight reduction is essential. (The FPCB market will increase by 10% annually. It will be worth 4.5 trillion yen in 2027.)

Millions of ¥

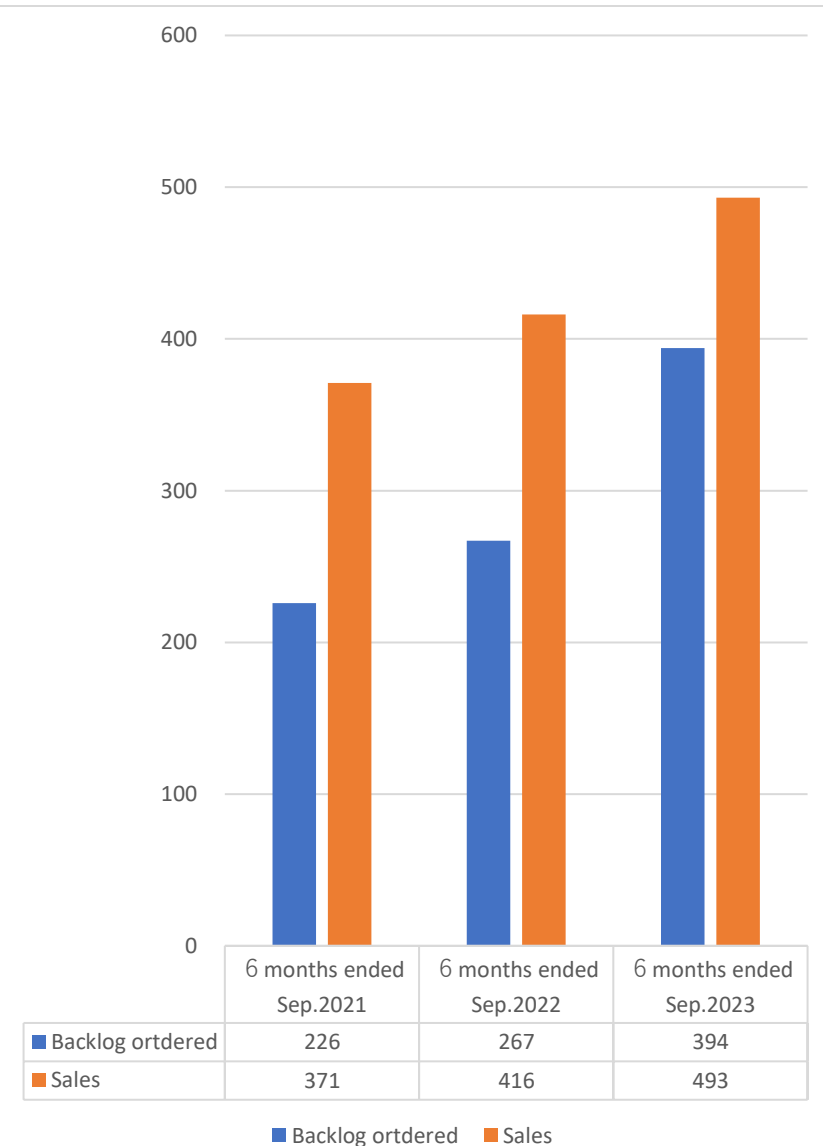

Segment information.

4 - ④ Electronics related business.

OHKURA Akihiro,

**Director & Senior managing operating
officer,**

Y.A.C. HOLDINGS CO., LTD.

**Representative Director and President,
Ohkura Electric Co., Ltd.**

4 - ④ Electronics related business 1st half of year analysis

6 months ended Sep. 2023

① In the electronics related business as a whole, the production of dialysis machines, which had been struggling due to procurement of parts, has stabilized, and electricity-related sales went stably. As a result, sales and profits increased compared to the same period last year.

② Medical Division: Demand for dialysis machines will continue to be strong mainly in Central and South America.

Reducing procurement costs and improving productivity are challenging points but there is a room to improve.

③ Control communication, industrial instrumentation sector: Renewable energy related new capital investment will continue, by industrial plans due to restart of nuclear power plants, sales of industrial instruments will increase.

④ Although there is a feeling of relief in the semiconductor industry, however there is a backlog of orders mainly for equipment.

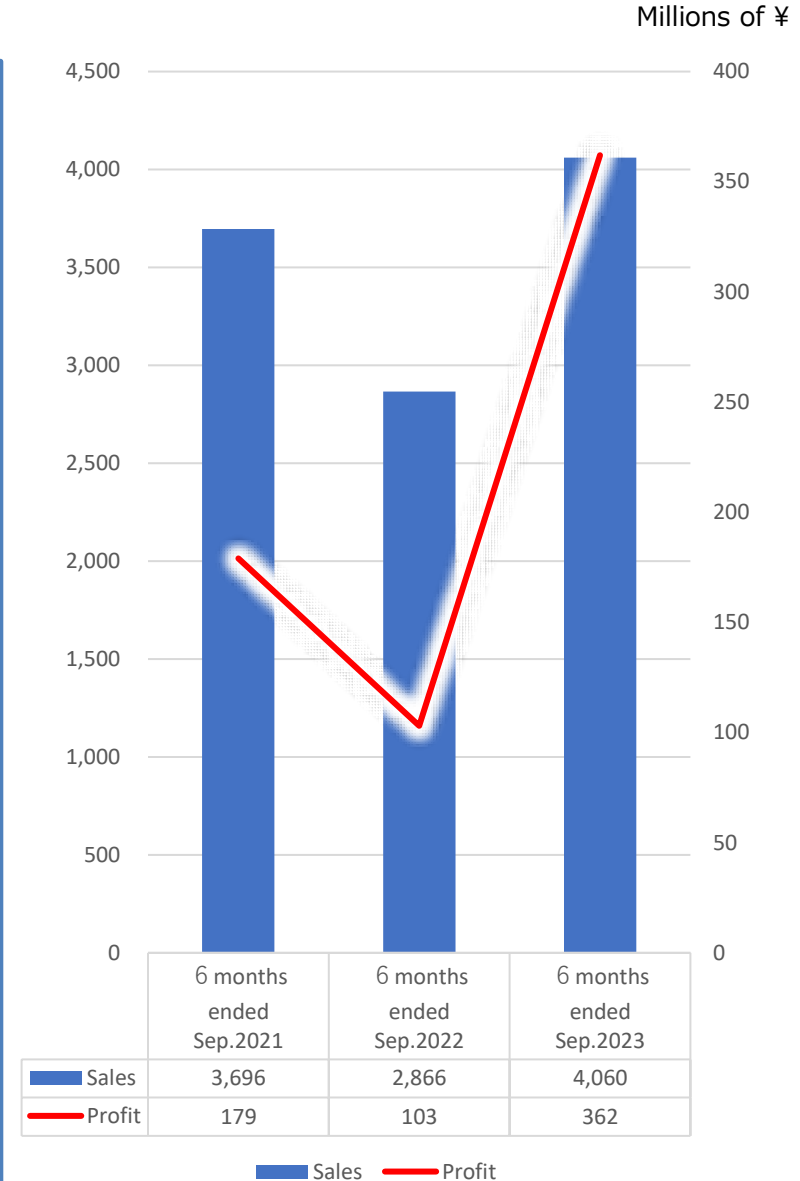

4 - ④ Electronics related business Target



Target of this FY and measures.

Sales: ¥9 Billion

Concerns

- ① Smooth material procurement and production system mainly on dialysis machines.
- ② Secure long-term delivery parts for semiconductor devices.
- ③ Secure personnel in response to labor shortages.

Measures

- ① Strengthen procurement capabilities as a group whole.
- ② Launch of new artificial dialyzer device.
- ③ Improving the efficiency of sales activities through sales DX.
- ④ Increase production of dialyzer, which are mass-produced products, by strengthen human resources.
- ⑤ Strengthen customer proposal sales.

Millions of ¥

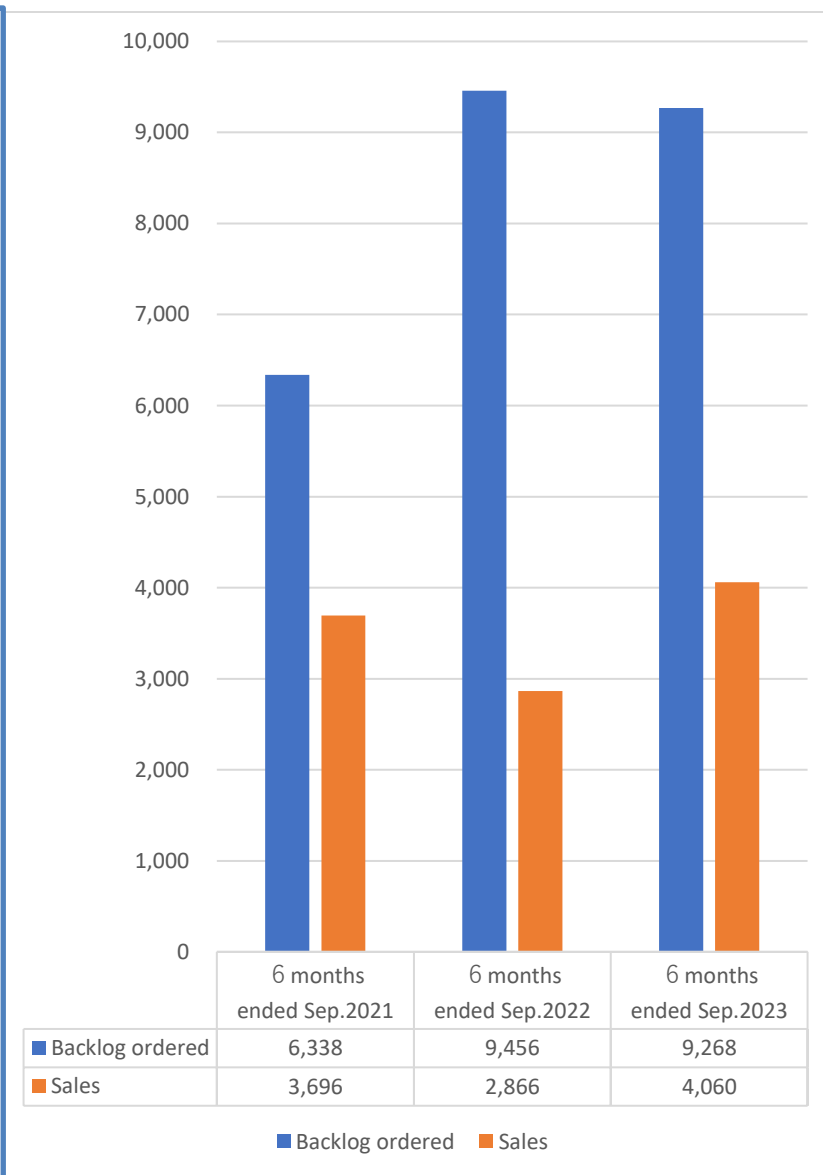

5. Summary of 2nd Q of FY Mar. 2024.

Year targets and strategies of FY Mar.2024.

MOMOSE Takefumi

Representative Director, Chairman and

President,

Y.A.C. HOLDINGS CO., LTD.

1. Management policy

(2) Corporate philosophy

Founding Philosophy (established in 1973)

Continuous
development

- ① Company with technology oriented.
- ② Company with strong vitality.
- ③ Company with challenging spirit against various risks.
- ④ Company with principal that small but highly skilled work force.

Philosophy for Growing (added in 1985)

Social
contribution

- ① Seeking employees prosperity, mentally as well as economically.
- ② Paying tax to central and regional government as much as possible.
- ③ Creating and delivering new products.
- ④ Treating shareholders highly and preferentially.
- ⑤ Contributing to social community.
- ⑥ Saving resources and energy for environment.

Ultimate Corporate Philosophy (added in 2020)

~ To contribute to society much more ~

SDGs

Towards a
sustainable
society

- ① Growth of employees' capacity and YAC group.
- ② All employee management , Cooperation and competition.
- ③ Promotion of SDGs management.
- ④ Expansion of paying tax.

5-② Our company which pursue our corporate philosophy.



1. Targets of our company in pursuit of our corporate philosophy.

a) Continuous develop.	For employee and their family.
b) Making loss is social ills.	Making loss is the most shameful for management.
c) Contribution to society.	Continuous growing and making profit.
d)SDGs	Towards a sustainable society, developing new mass products which are carbon neutral.
e) Prime market. Shareholders are mainly institutional investors.	Only growing, it's a destiny. Everybody is happy with growing.

2. What is our company group culture ?

We are the company group aiming growth and further growth, never giving up even in difficult situations, under the philosophy of all employee management, cheerfully and energetically, continuing to take on positive challenges, feeling the joy of growth, and contributing more to society.

2. Corporate outline

(3) Group companies

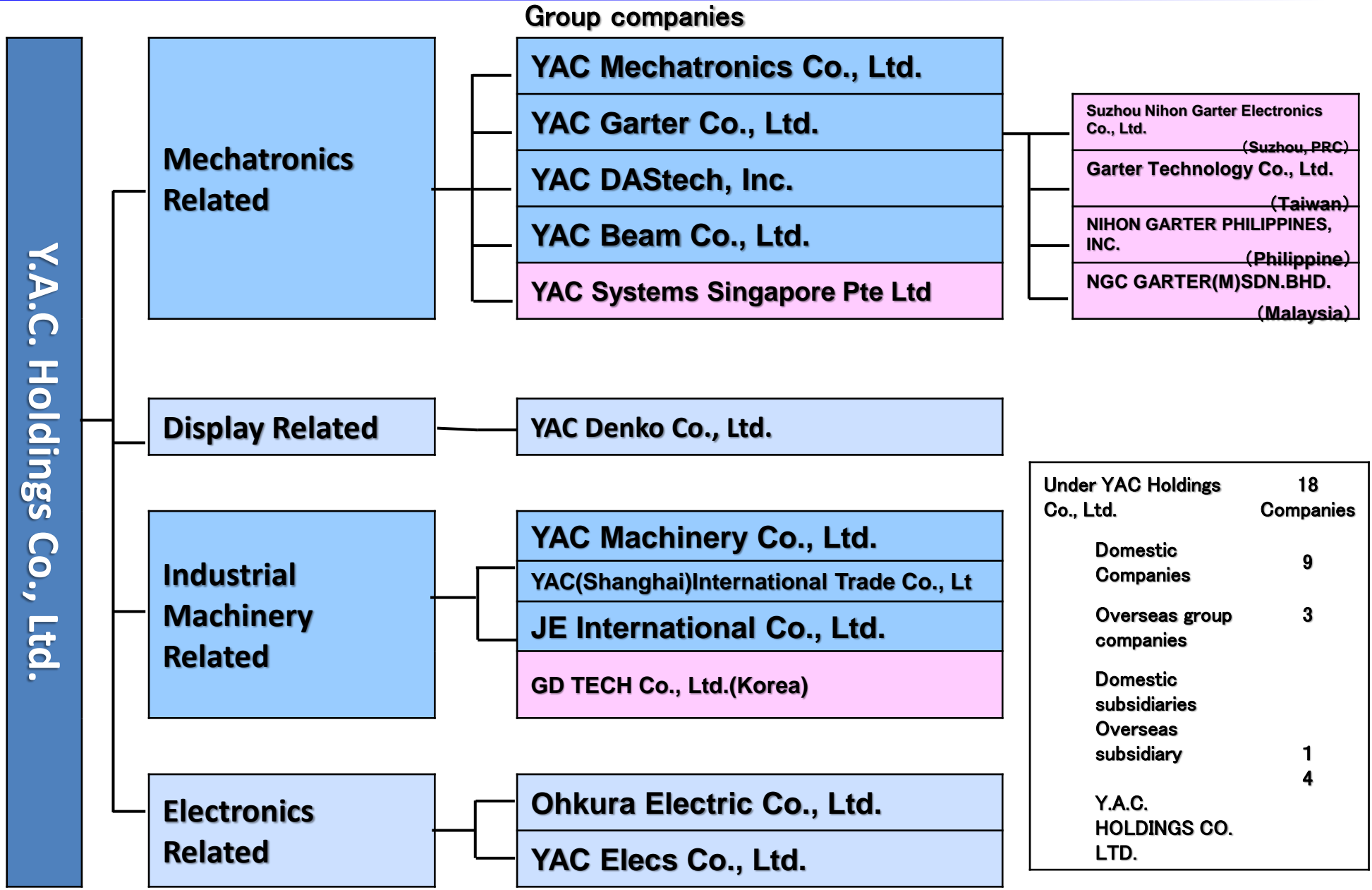

Under YAC Holdings Co., Ltd.	18
	Companies
Domestic Companies	9
Overseas group companies	3
Domestic subsidiaries	
Overseas subsidiary	1
	4
Y.A.C. HOLDINGS CO. LTD.	

5-④. FY of 50 years anniversary. Business forecast.



(1) Budget by segment, FY Mar.2024.

(Millions of ¥)

Segment	Sales budget FY 2023	Backlog ordered at the previous FY year end	Ratio of backlog to sales budget
Mechatronics	13,500	7,512	55.6%
Display	6,000	8,542	142.4%
Industrial machinery	1,500	144	9.6%
Electronics	9,000	9,286	103.2%
Total	30,000	25,485	85.0%

Full year forecast	Sales	Operating income	Ordinary income	Profit for the period	Profit per share
Forecast	30,000	3,000	2,900	2,100	¥228.64
Change rate compared to previous period	24.4%	100.5%	88.1%	128.0%	—

5-⑤. Strategies to achieve the targets.



(2) FY Mar.2024, strategies to go exceed the budget.

(1) To promote 4 big theme (Appointment of promotion committee members)

1. Marketing innovation.	<ul style="list-style-type: none">① Increasing the number of contacting points.② Organized sales activities and Increase efficiency.
2. Gross margin up.	<ul style="list-style-type: none">① Complete execution of ordered budget system.② Operating ratio up.③ Mistake prevention.
3. Cost reduction and quick collection.	<ul style="list-style-type: none">① Expense : Maintain under the budget.② Receivables of sale : Collect as the schedule.
4. All employee management.	<ul style="list-style-type: none">① Workplace communication.② full of enthusiasm.③ A sense of unity in the workplace to exceed goals.

(2) Promotion of B to C business.

1. Co-operation business with Linus.

2. Alzheimer type dementia biomarker measuring device.

1. Basic strategy for growth.

(1) Sectoral ratio to growth.

① Growth in existing fields.	5% upper. (+¥5 billion by 2030.)
② Growth through the completion of mass-produced new production.	60% upper (+¥45 billion by 2023.)
③ M&A and alliance.	30% upper. (+¥25 billion by 2023.)

(2) More than 6 group companies annual sales exceeding ¥10 billion.

(3) Every employee propose regularly the needs of mass production.

(4) Y.A.C. Group's company that challenge to exceed 10 billion yen (high possibility)

① Dialyzer	Elecs (Mr.Hanaki)
② Joint business with Linus	Project (Mr. Takahashi, Leader)
③ Display	Denko (Mr.Aoki)
④ Carrier tape	Garter (Mr.Shirai)
⑤ Power semiconductor..... (Lazer annealer, SiC chip handler)	Beam(Mr.Yoshida),Mech atronics(Mr.Ogiue)
⑥ SDGs	Machinery (Mr. Soejima)
(Packaging machine for EC distribution using paper and biodegradation)	
⑦ Alzheimer's type dementia detection device...	New Business Development Department
⑧ AOI(Automatic optical inspection equipment) ..	JEI(Kin,President)

Business with Linus Bio.

1. Basic contract. ...Proceeding the joint business between the two companies.(We invested ¥1 billion.)

2. Description of business...· Inspection for various diseases.

<Diseases targeted for the time being>

①Autism

④PD (Parkinson's disease)

②ALS (Amyotrophic lateral sclerosis)

⑤Cancer

③ADHD (Attention deficit hyperactivity disorder)

⑥ glioblastoma

3. Our sales target

① Equipment manufacturing ③ Consumables

②Commission

④After-sales service

**4. Business in the Asian region will be managed by our company (led by Lynas)
(U.S., EU, and Middle East operated mainly by Lynas)**

(1)Facility.

(2) Operation of inspection business.

①Hair acceptance (paid).

④Send data to Linus.

② Execution of inspection.

⑤Judge by Linus based on the data.

③ Aggregation of test results.

⑥ Feedback of inspection results.

To the 100th anniversary (year of 2073)

Aim to over ¥3 Trillion of sales.

1. Expansion of ongoing 10 billion yen project.

- | | |
|-------------------------|-------------------------------------|
| (1) Linus | (5) Carrier tape |
| (2) Biodegradation | (6) Display |
| (3) Dialyzer | (7) Dementia early detection device |
| (4) Power semiconductor | (8) AOI |

2. Change of business model.

- (1) Aggressive expansion from small-lot products to mass-produced products
- (2) Aggressive expansion to B to C in addition to B to B

3. M & A and Alliance.

4. Always focus on grasping the needs of mass-produced new products.



APPENDIX

6-①. The target of FY Mar.2024.(Business plan)



	FY Mar.2021 Results.	FY Mar.2022 Results.	FY Mar.2023 Results.	FY Mar.2024 Forecast.	YoY comparison amount forecast.	YoY comparison ratio forecast.
Sales	24,195	22,796	24,114	30,000	5,885	24.4%
Operating income	727	1,566	1,495	3,000	1,504	100.5%
Ordinary income	739	1,491	1,541	2,900	1,359	88.2%
Profit for the period	337	1,107	921	2,100	1,178	128.0%
Profit per share	37.19	121.49	100.57	228.64	128.07	127.3%
Annual cash dividend per share	20.00	36.00	75.00	75.00	0.00	0.0%

Including 50th anniversary
commemorative dividend

6-② New order received and backlog ordered by business. (Consolidated)



(Millions of ¥)

		6 months ended from Apr.1, 2022.	6 months ended from Apr.1, 2023.	YoY comparison amount .	YoY comparison ratio.
Mechatronics related.	New order received	7,447	4,928	-2,518	-33.8%
	Backlog ordered	6,792	7,462	670	9.9%
Display related.	New order received	2,718	632	-2,085	-76.7%
	Backlog ordered	6,869	7,201	331	4.8%
Industrial machinery related.	New order received	560	743	183	32.7%
	Backlog ordered	267	394	127	47.6%
Electronics related.	New order received	4,460	4,043	-417	-9.4%
	Backlog ordered	9,456	9,268	-187	-2.0%
Total	New order received	15,187	10,348	-4,838	-31.9%
	Backlog ordered	23,385	24,327	942	4.0%

The same period last year was a special factor.



< Relationship between backlog of orders at the end of the previous fiscal year and sales for the current fiscal year >

(Millions of ¥)
40,000

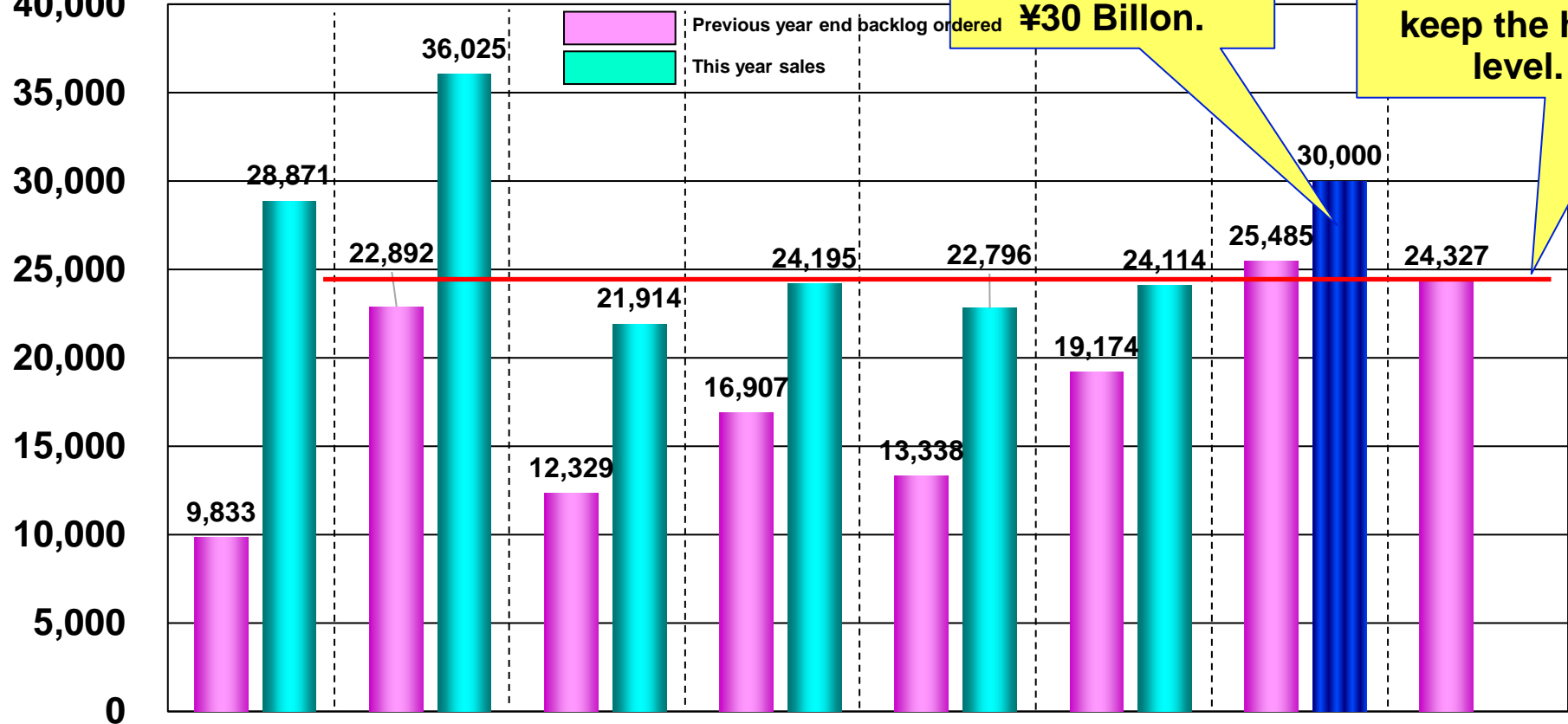

FY Mar.2024 sales forecast ¥30 Billion.

End of Sep. 2023 backlog ordered still keep the high level.

■ Multiplier that shows how many times the current period's sales have increased compared to the backlog of orders at the end of the previous period.

2.94 times	1.57 times	1.78 times	1.43 times	1.71 times	1.26 times	?
------------	------------	------------	------------	------------	------------	---

6-④. Business results



(Millions of ¥)

	6 months ended from Apr.1, 2022.	6 months ended from Apr.1, 2023.	YoY comparison amount .	YoY comparison ratio.
Sales	10,976	11,506	530	4.8%
Operating income (Ratio)	473 (4.3%)	710 (6.2%)	237	50.2%
Ordinary income	577	861	283	49.1%
Profit attributable to owners of parent	325	700	374	115.1%
Profit per share (¥)	35.61	76.30	40.69	114.3%

6-⑤. Sales and profit by business.



(Millions of ¥)

		6 months ended from Apr.1, 2022.	6 months ended from Apr.1, 2023.	YoY comparison amount .	YoY comparison ratio.	Remarks
Mechatronics related	Sales	5,719	4,978	-201	-3.9%	Sales of automatic transport equipment and ion beam milling equipment were strong. Profit margin improved.
	Profit	469	580	111	23.7%	
Display related	Sales	2,513	1,973	-540	-21.5%	The Chinese display market is on a slowing trend.
	Profit	-131	248	379	—	
Industrial machinery related	Sales	416	493	76	18.5%	Aiming to enter into the e-commerce logistics market. AI optical inspection equipment is struggling.
	Profit	-17	-244	-227	—	
Electronics related	Sales	2,886	4,060	1,194	41.7%	Sales to electric power companies and dialyzer went stable.
	Profit	103	362	258	249.5%	
HD and others	Profit	48	-236	-285	—	
Total	Sales	10,976	11,506	530	4.8%	
	Profit	473	710	237	50.2%	

6-⑥. Historical comparison of B/S



<Assets>

(Millions of ¥)

	As of Mar.31, 2023	As of Sep.30, 2023	Increase/ decrease	Remarks
Cash and deposits	6,628	5,832	-795	
Accounts receivable	11,282	11,405	123	
Inventories	11,181	13,287	2,105	Active purchasing for long-term delivery
Other current assets	1,015	1,066	50	
Noncurrent assets	8,631	10,573	1,941	Invest to Linus.
Total assets	38,740	42,165	3,424	

<Liabilities and Net Assets>

(Millions of ¥)

	As of Mar.31, 2023	As of Sep.30, 2023	Increase/ decrease	Remarks
Account receivable trade	5,252	6,032	780	
Other current liabilities	8,428	11,240	2,812	Increase of short term loans payable
Fixed liabilities	9,082	8,375	-707	
Net assets	15,977	16,517	539	
Total liabilities and net assets	38,740	42,165	3,424	

6-⑦. Progress of sales budget of FY Mar.2024.



<FY Mar. 2024 progress of sales budget by business>

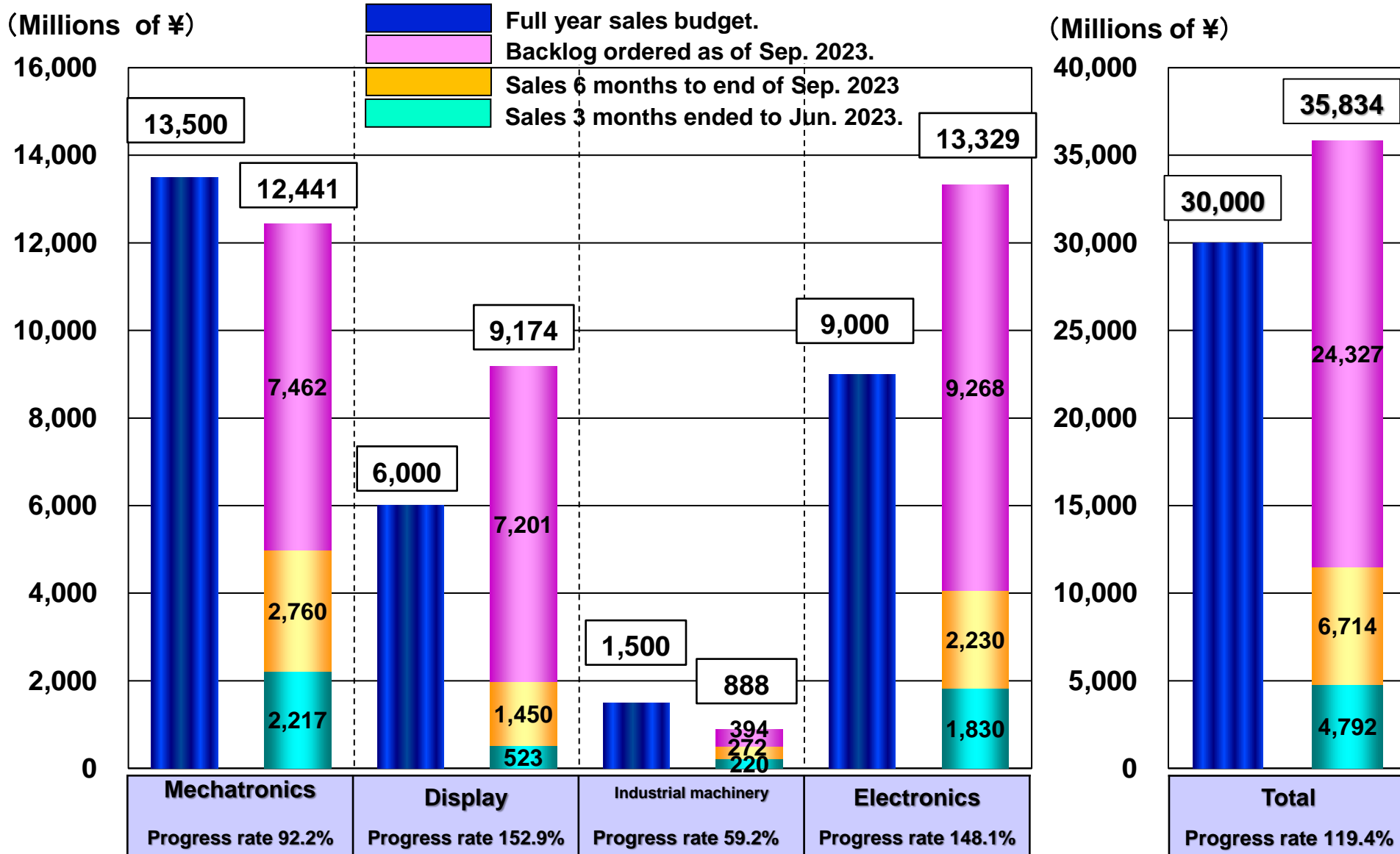

6-⑧. Sales by quarter.



<reference> Past quarterly sales trends.

(Millions of ¥)

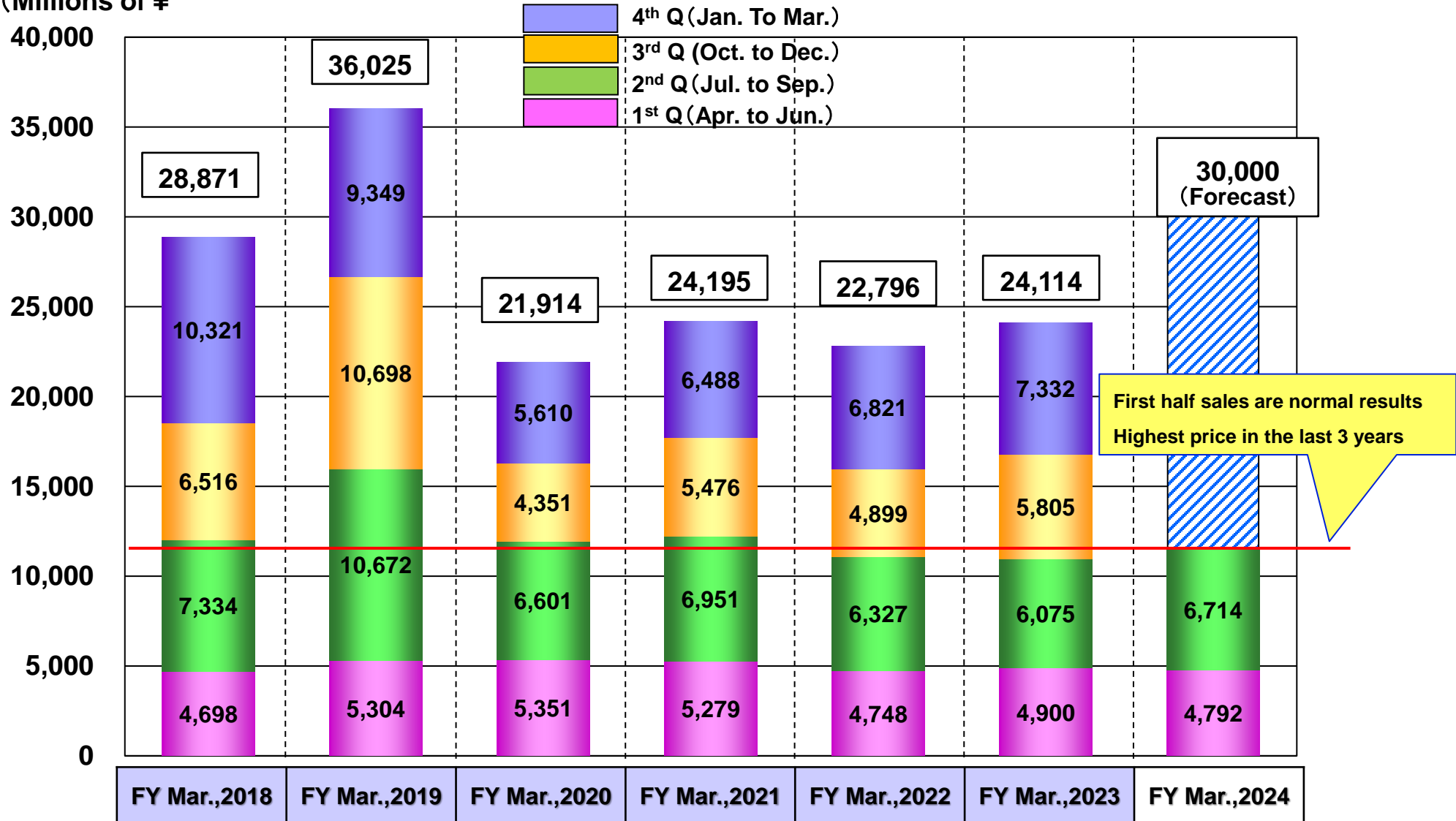

6-⑨ Quarterly sales by business.

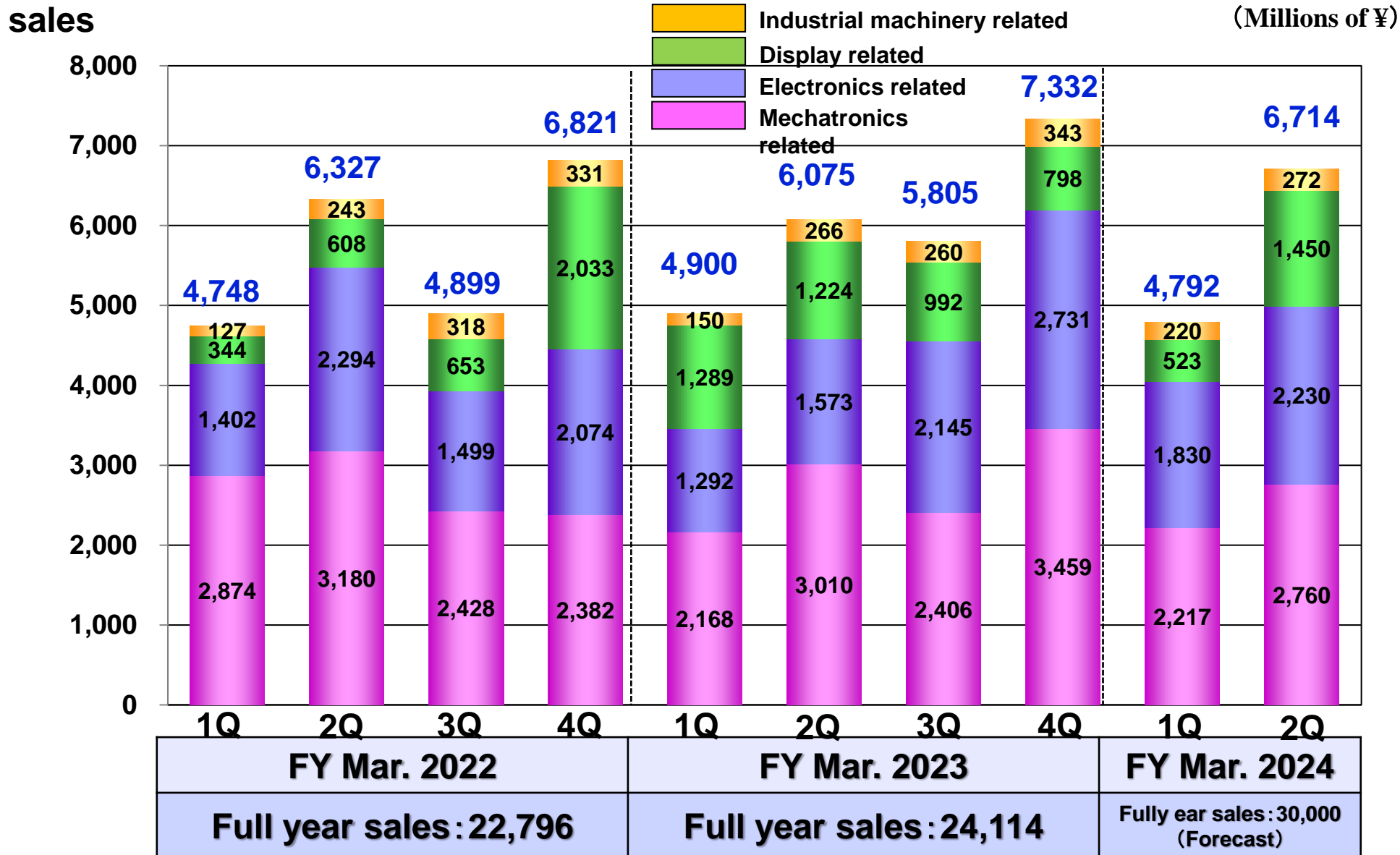

6-⑩. New order received by quarter.



<Reference> Past trends in quarterly new orders received

(Millions of ¥)

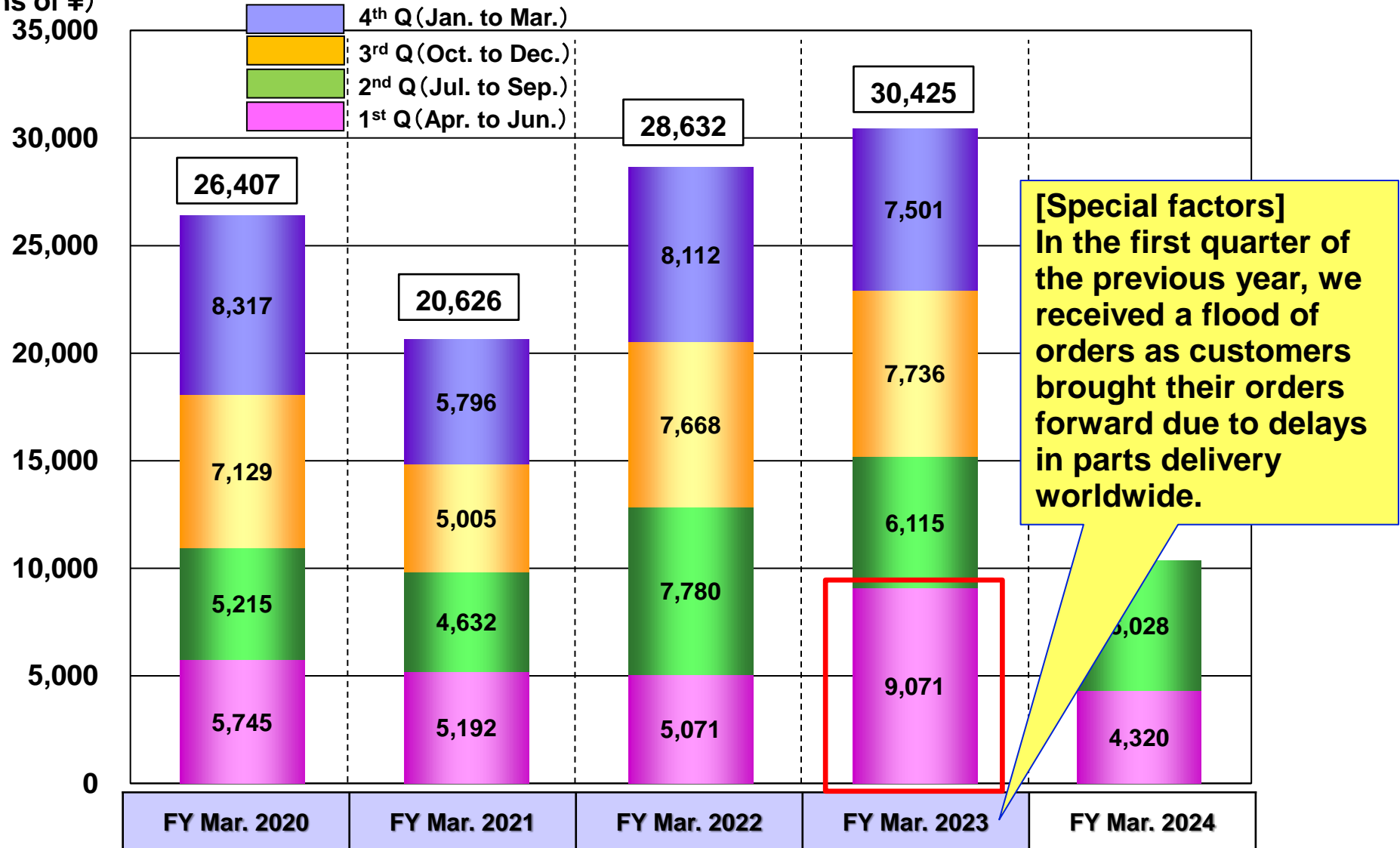

6-11. Quarterly new order received by business.



New order received.
10,000

(Millions of ¥)

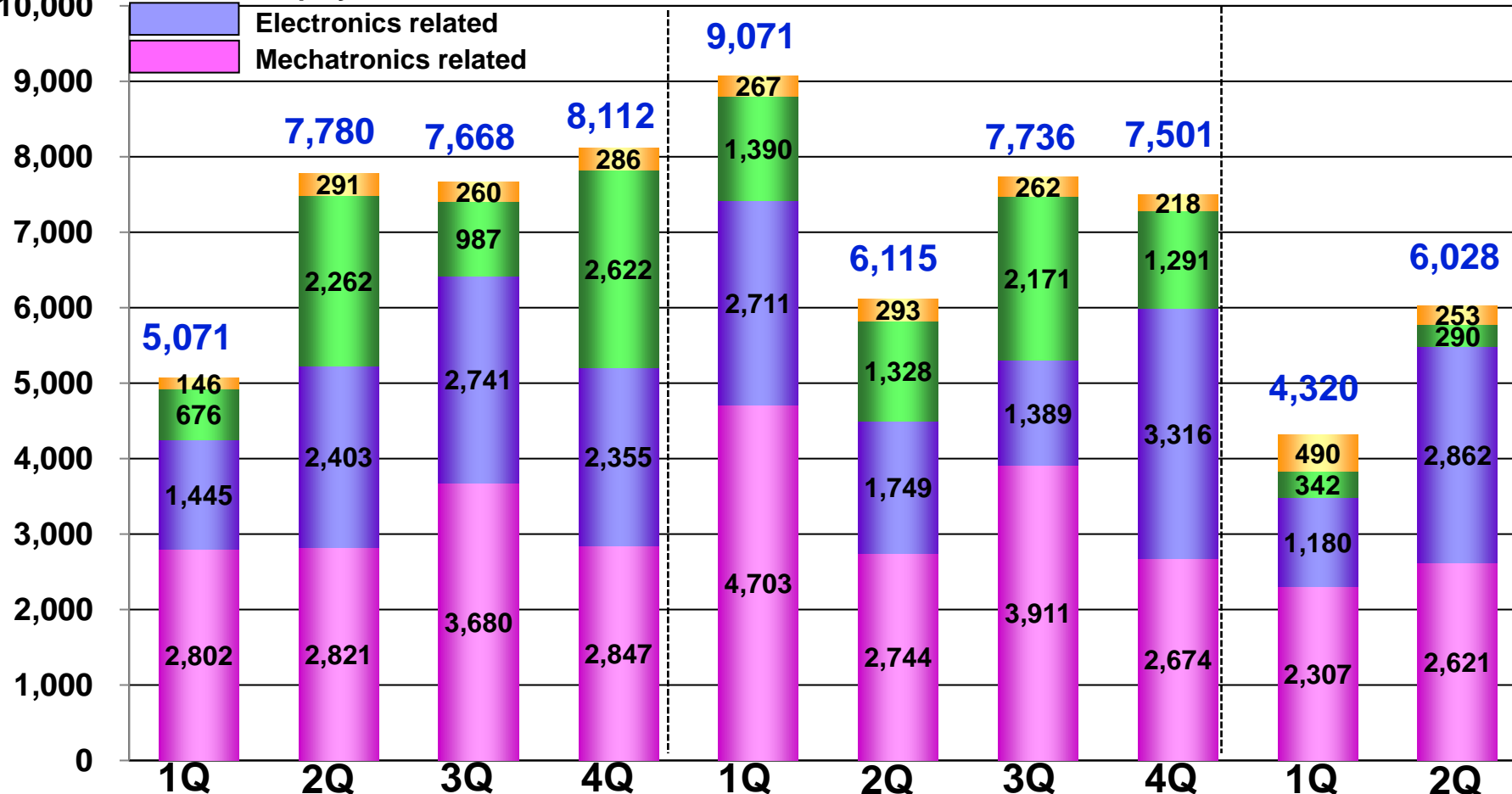
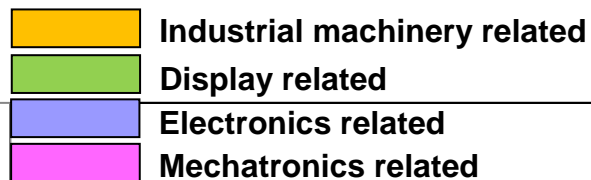

FY Mar. 2022	FY Mar. 2023	FY Mar. 2024
Full year : 28,632	Full year : 30,425	



Well, Today should be

a Fascinating and Prosperous

Day, again !

Flexible high technology company



Y.A.C. Group